

MOS Series Pump Protection / Monitoring Modules

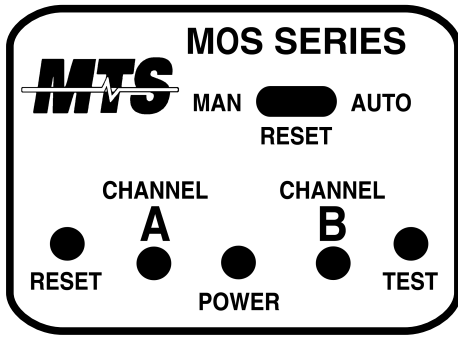

Base Part Numbers: MOS-1P, MOS-1PE, MOS-1PR, MSS-2P, MSS-2PE, MSS-2PR, MTT-2P, MRS-1P, MRS-1PE, MRR-2P, MRT-1P



Model Variations (Channel Usage)

The MOS channels (A and B) may be used independently in any combination, as shown in the following table.

Model	Channel A	Channel B
MOS-1P	100K resistance probe (seal-fail)	NC Klixon™ (thermal)
MOS-1PE	NC seal chamber float switch (seal-fail)	NC Klixon™ (thermal)
MOS-1PR	33k parallel resistor with 100k resistance probe (seal-fail)	NC Klixon™ (thermal)
MSS-2P	100K resistance probe (seal-fail)	100K resistance probe (seal-fail)
MSS-2PE	NC seal chamber float switch (seal-fail)	NC seal chamber float switch (seal-fail)
MSS-2PR	33k parallel resistor with 100k resistance probe (seal-fail)	33k parallel resistor with 100k resistance probe (seal-fail)
MTT-2P	Thermistor DIN44082/01D463 (thermal)	Thermistor DIN44082/01D463 (thermal)
MRS-1P	100K resistance probe (seal-fail)	Pt100 RTD (thermal)
MRS-1PE	NC seal chamber float switch (seal-fail)	Pt100 RTD (thermal)
MRR-2P	Pt100 RTD (thermal)	Pt100 RTD (thermal)
MRT-1P	Thermistor DIN44082/01D463 (thermal)	Pt100 RTD (thermal)

Overview

The MOS Series pump protection and monitoring modules are designed to provide a low-cost, flexible solution for protecting most brands of submersible sewage pumps against thermal and seal-failure conditions. Separate LED indication and relay contact outputs for each function are included. Flexible model options enable protection of any submersible sewage pump with heat sensor and/or seal-failure sensing devices installed. The MOS Series may be powered by 24 to 240 VAC, 50/60 Hz with no modifications. Standard models are available for monitoring via resistance probes, seal-failure float switches, Klixon thermal switches, RTDs and thermistors. Custom modules may also be factory configured.

Operation Description

The MOS Series combines detection circuits for both motor and bearing over-temperature and seal-failure in a single plug-in unit. In an alert condition, the appropriate LED is illuminated and relay contacts associated with the condition toggle. Thus a load, such as the motor contactor, may be turned off, or a warning light might be turned on. Upon occurrence of the first alarm condition, the proper LED will illuminate a steady alarm indication. If the alarm is cleared automatically, the LED will then begin to flash, so that the operator will know that one or more alarm occurrences has been detected, and automatically cleared.

A low voltage supply provides power to the over-temperature and seal-failure monitoring circuits which control relay outputs based on instructions contained in a microprocessor. The microprocessor circuitry includes power-on-reset and oscillator start-up timers as well as an independent watchdog timer to ensure reliable operation. Both hardware and software filtering is implemented on the sensor inputs for reliable signal integrity in noisy environments.

A Test push button simulates faults on both sensor channels, and a Reset push button clears the alert indicators after (1) The Test push button has been depressed, or (2) an actual alert has been corrected. The Reset push button performs a "hard" microprocessor reset.

To prevent dislodgement of the module it is designed to be mounted in an industrial type 12-pin socket with hold down clip.

Common Features (All Models)

- ◆ **Auto/Manual Reset:** Channels that monitor temperature can be set for Manual or Auto reset after experiencing an alarm condition. (Seal failures automatically reset when the alarm condition is removed although the LED continues to flash until reset.)
- ◆ **Reset Push-button:** The reset button is used to reset all alarm conditions and clear flashing LED states.
- ◆ **Test Push-button:** The test button simulates an alarm condition in both channels until released. NOTE: In many cases this will cause the pump to stop because of the simulated high temperature condition.

Technical Specifications

Mechanical

Measurement Principle	Current sensing.
Environment	-40 to 55 °C (-40 to 131 °F)
Supply Voltage	24 to 240 VAC, 50-60 Hz. / 24-48 VDC
Power Consumption	24 VAC - 50/60 Hz 1.7 VA 120 VAC - 50/60 Hz 1.9 VA 240 VAC - 50/60 Hz 2.4 VA 24 VDC 1.4 Watts
Relay Contact Rating	NEMA B300 Pilot Duty, 1/6th HP, 3A @240VAC; Form C
Sensor Voltage	Varies with resistance. Not to exceed 10 VDC±2%
LED States (Both Channels)	GREEN: no fault RED: thermal fault AMBER: seal-fail fault FLASHING: fault automatically cleared
Contact States	N.O. contact closes on fault condition or on loss of supply power.

Model	Channel A		Channel B	
	Fault	Timing	Fault	Timing
MOS-1P	R < 120k (seal-fail)	45 sec. or 3 15-sec. events in 24 hours	Klixon™ open (thermal)	7 sec. event
MOS-1PE	Float switch opens (seal-fail)	45 sec. or 3 15-sec. events in 24 hours	Klixon™ open (thermal)	7 sec. event
MOS-1PR	R < 26k or R > 40k (seal-fail)	45 sec. or 3 15-sec. events in 24 hours	Klixon™ open (thermal)	7 sec. event
MSS-2P	R < 120k (seal-fail)	45 sec. or 3 15-sec. events in 24 hours	R < 120k (seal-fail)	45 sec. or 3 15-sec. events in 24 hours
MSS-2PE	Float switch opens (seal-fail)	45 sec. or 3 15-sec. events in 24 hours	Float switch opens (seal-fail)	45 sec. or 3 15-sec. events in 24 hours
MSS-2PR	R < 26k or R > 40k (seal-fail)	45 sec. or 3 15-sec. events in 24 hours	R < 26k or R > 40k (seal-fail)	45 sec. or 3 15-sec. events in 24 hours
MTT-2P	R > 4k 130°C nom. (thermal)	7 second event	R > 4k 130°C nom. (thermal)	7 sec. event
MRS-1P	R < 120k (seal-fail)	45 sec. or 3 15-sec. events in 24 hours	R > 150 130 °C nom. (thermal)	7 sec. event
MRS-1PE	Float switch opens (seal-fail)	45 sec. or 3 15-sec. events in 24 hours	R > 150 130 °C nom. (thermal)	7 sec. event
MRR-2P	R > 150 130 °C nom. (thermal)	7 sec. event	R > 150 130 °C nom. (thermal)	7 sec. event
MRT-1P	R > 4k 130°C nom. (thermal)	7 second event	R > 150 130 °C nom. (thermal)	7 sec. event

NOTE: Timing values are nominal. Hardware and digital filtering will affect absolute response times by as much as 3 seconds total.

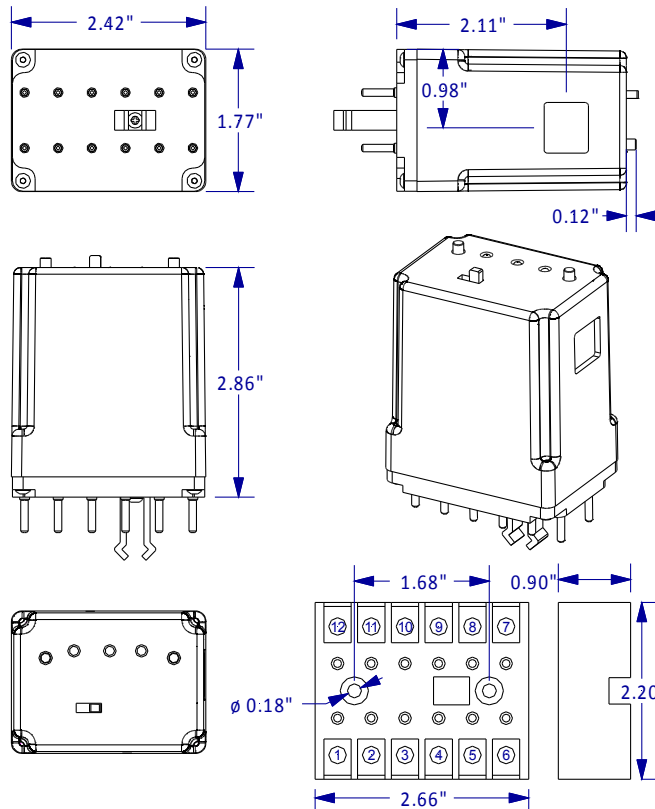

Electrical Wiring

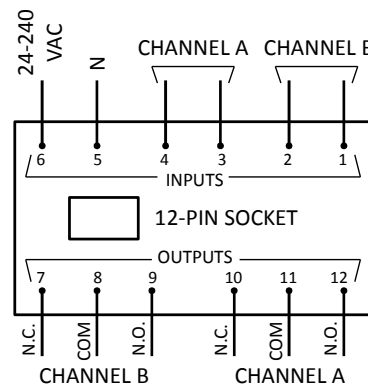

* On 1-wire seal-fail circuits attach Pin 4 to COMMON GROUND point with PUMP SAFETY GROUND WIRE.

NOTE: N.O. contact closes on fault or loss of supply power.



MOS Series Pump Protection / Monitoring Modules

Modbus™ Communication Option Datasheet Addendum



Base Part Numbers: MOS-1P, MOS-1PE, MOS-1PR, MSS-2P, MSS-2PE, MSS-2PR, MTT-2P, MRS-1P, MRS-1PE, MRR-2P, MRT-1P
Suffixes: -M (Modbus™ over RS-485 Option)

Overview

The MOS Series pump protection and monitoring modules may be optionally purchased with a Modbus™™ over serial RS-485 Option. The advantage is that a single Modbus™™ host may control and/or monitor operation of several devices over a single multi-drop communication channel.

This datasheet describes the configuration and use of that option.

Revision Level

This document applies to MOS firmware revisions 1.13 and higher.

Modbus™ Architecture

From a logical perspective, Modbus™™ consists of a single bus master talking in a master-slave relationship to multiple slaves over a single communication bus. All communication is initiated by the master. The MOS uses an RS-485 communication bus.

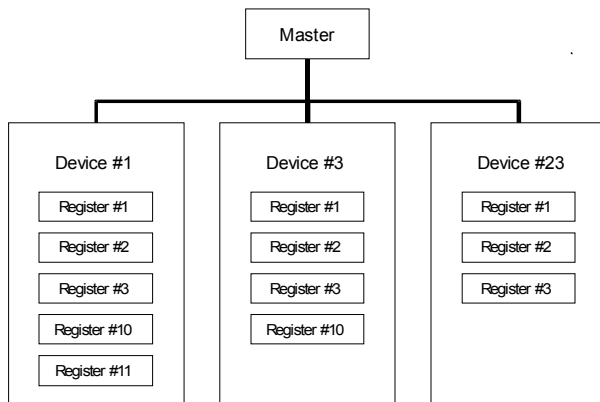

Illustration 1: Example Modbus™ Architecture

Each slave has a unique address and a series of 16-bit registers which may be read and/or written by the Modbus™™ master. So each register read requires a unique set of addresses -- Serial Device Address and Register Address.

Modbus™ Hardware Connection

The standard bus protocol is Modbus™™ RTU (binary mode) with 19,200 baud, 8 data bits, EVEN parity, and one stop bit (19.2k,8,E,1) -- the Modbus™™ default configuration. This can be changed by the user via the Modbus™™.

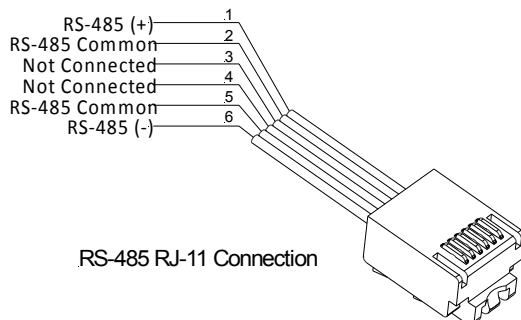

Illustration 2: Modbus™™ Cable Wiring

RS-485 requires three wires -- RS485+, RS485-, and Ground. The MOS

uses an RJ-11, six-wire connection to bring these signals out. Illustration 2 shows the connections from the cable perspective.

RS-485 specifies line termination requirements, but in practice at the two baud rates (9600 and 19200) available, termination is generally not required for distances less than 300 m (1500 ft.). The MOS does not incorporate internal termination.

Modbus™ Electrical Grounding

The MOS references its internal ground signal to pins #2 and #4 on the relay base. It is recommended that either pin #2 or pin #4 be referenced to chassis or panel ground. NOTE: In the case of a one-wire moisture probe, pin #4 is typically connected to panel ground. In isolated two-wire sensor configurations, either pin #2 or pin #4 should be connected to panel ground. Devices on the RS-485 bus must reference this same panel ground or be guaranteed to stay within a maximum of ± 7 volts of panel ground for proper operation. Ground voltages outside of this range will produce unpredictable results and may result in hardware damage.

In practice, all devices on the RS-485 bus should tie their zero volt potential to the panel ground. In this case only pins #1 and #6 on the RJ-11 connector are required. If a device is floating on the bus, then pins #2 and #5 may be used to pull that device to the panel ground. These pins are common with the MOS internal ground signal.

If the RS-485 bus is transmitted over long distances, then the engineer must ensure that either the remote device is guaranteed to stay within the allowed ground potential range or an isolated RS-485 repeater must be installed. Devices are commercially available. In all cases, proper care should be taken to avoid grounding conflicts and ground loops.

Modbus™ Commands

Modbus™™ provides various commands to read and write register banks. The MOS decodes commands 3, 4, 6, and 16 (0x03, 0x04, 0x06, and 0x10 hexadecimal). Commands that can read / write multiple registers (vectors) must only be used to access a single register per command. Attempts to read / write multiple registers in a single command will produce an error response. If the master implements both commands 6 and 16, then command 6 is preferable since it can only write to a single register and will avoid this error.

RS-485 specifies line termination requirements, but in practice at the two baud rates (9600 and 19200) available, termination is generally not required for distances less than 300 m (1500 ft.). The MOS does not incorporate internal termination.

Getting Started -- Reading the Firmware Revision Level

By convention Modbus™™ starts register numbering at #1, but some systems use an internal register numbering system that starts with #0. The communication channel between the MOS and the master can be tested by reading the firmware revision level -- Register #1. The result should be 113 (decimal).

If the register read fails, check that the baud rate, the target address, and the parity are correct. Check wiring for proper polarity between the master and the MOS.

If the result returns 0 or 1, change the register read to Register #0. There may be a discrepancy between the master and the MOS in register numbering systems. If the command then returns correctly, then remember to subtract 1 from all register addresses in future read / write operations.

Once the firmware is successfully confirmed, you are ready read other registers.

Reading the PumpSafe Status Register

The current state of the MOS may be read by reading the **Status Register** -- Register #42.

This register uses bit encoding to track various internal states. Some bits may be used by the master to decode the present state.

Note that the information in this register is encoded in individual bits, so the master must either use bit specific commands to interpret the data or use bit-wise AND operations to mask off the unused bits. Bits are labeled 0 to 15 from least significant to most significant order. That is bit #0 corresponds to 1 while bit #15 corresponds to 32,768 (decimal).

Bit	Description
4	Channel B fault condition (1 = FAULT)
5	Channel A fault condition (1 = FAULT)
6	Channel B fault condition latched (1 = FAULT has occurred)
7	Channel A fault condition latched (1 = FAULT has occurred)
12	Test switch state (1 = Test switch pressed)
13	AUTO / MAN switch state (1 = AUTO)
14	Power On Reset (1 = power up occurred since bus reset)

Latches allow an automatically cleared fault state to be recognized.

Power On Reset is set on a unit hard power-up. This can only be cleared by a Modbus™ master.

Other bits have internal usage within the MOS and should be ignored.

Do not write to the Status Register.

Resetting Fault Conditions

Register #43 is used to clear fault conditions. Bits in this register are used to individually reset the two fault conditions and the power-on-reset flag.

Bit	Description
0	Channel B fault condition Reset (1 = RESET)
1	Channel A fault condition Reset (1 = RESET)
2	Power On Reset (1 = RESET)

Bits may be written individually or concurrently for any combination of reset actions. Write 7 to this register to clear all faults and the Power On Reset flag.

Reading Configuration Type and Date

MOS models are assigned a unique electronic configuration number, which may be read in Register #32.

The configuration date is encoded in Register #33.

The configuration date is encoded into a 16-bit value by the following formula.

$$DateCode = (year - 2000) * 1000 + day$$

So a value of 9125 corresponds to the 125th day of 2009. Date codes up to 2065 can be encoded in this way.

Reading the Fault Counters

Channel A and B faults are logged in non-volatile memory so that faults can be tracked over the life of the product. These counters may not be field reset.

Register #30	Channel B fault total
Register #31	Channel A fault total

Power-on-reset Counters

Over the life of the product it may be useful to know the number of times the MOS experiences a power-on-reset. This occurs under two circumstances: a recovery from a power outage or the manual reset

button is pressed.

Two registers store this information.

Register #34 and Register #35 combine to form a 32-bit counter.

Register #34 is the low-order portion of the counter. The total number of resets may be determined by reading both registers and using the following formula.

$$Resets = (Register35 * 65536) + Register34$$

For most cases, simply reading Register #34 will suffice.

Raw Analog Data

The MOS uses a 10-bit analog to digital converter with digital filtering on both Channel A and Channel B. This data may be read directly in Register #39 and Register #36 respectively. Interpreting this data requires some technical knowledge of the internal circuitry. Consult the factory for details.

User Configuration -- Protocol and Serial Address

The user may configure the MOS by changing the Modbus™ serial address and the serial port protocol. This is a more advanced process than reading registers and clearing faults. Some care should be taken in attempting this. Please read the following carefully before attempting to alter these values. Changing these values will cause the unit to immediately respond to its new address or serial protocol. Erroneously changing these values may result in the unit becoming unresponsive to further commands.

Two registers are provided for this.

Register #3 is the **serial address register**. This defaults to 1 from the factory. This may be modified to any valid Modbus™ device address (1 to 247), but once modified the unit will no longer respond to the default address of 1.

Register #4 is the **serial protocol register**. This defaults to 19200, 8, E, 1 according to Modbus™ standards. But it may be changed to any of the following values.

Value	Protocol	Value	Protocol
0	9600,8,N,2	1	19200,8,N,2
2	9600,8,E,1	3	19200,8,E,1
4	9600,8,O,1	5	19200,8,O,1

Like the serial address, changing this results in a valid Modbus™ response at the old protocol, but then the unit is immediately changed to the new protocol. Therefore, the master must be capable of changing its protocol accordingly.

Safety Unlock Procedure

Since changing the serial address and the serial protocol can permanently alter the MOS Modbus™ behavior, safety procedures have been incorporated to prevent accidental corruption. To write to either Register #3 or Register #4, first an unlock procedure must be performed. This consists of writing an unlock key into Register #44 followed immediately by the write to Register #3 or Register #4. The unlock key must be sent before each write. A successful write to either Register #3 or Register #4 will reset the unit to a locked state. The unlock key is 0x5aa5 (hexadecimal) or 23205 (decimal).

So, as an example, if the serial address is to be changed to 16, first write 23205 to register #44 then immediately write 16 to Register #3. The unit will respond via normal Modbus™ protocol after the second write. But from this point, it will only respond to address 16.